

V-IPLINK

Multi-mode video content transmission platform



V-IPLink is the next-generation, ATSC 3.0-ready digital microwave system. This IP-centric solution is specifically designed to meet broadcasters' studio-to-transmitter requirements.

The 2RU chassis combines sleek design with the reliable performance of a modern broadcast microwave system.

The streamlined physical design features integrated TX/RX transceivers within a single enclosure, complemented by front-panel touchscreen display for monitoring critical performance metrics and alarms. This modular platform offers a highly adaptable and configurable solution, tailored to meet a wide range of customer requirements.

The system delivers enhanced RF gain performance through improvements in linearization and LDPC forward error correction (FEC) which reduces the incidence of packet loss over long or unreliable transmission paths.

V-IPLink offers increased data throughput by utilizing modulation up to 1024QAM with XPIC (cross-polarization interference cancellation). XPIC is a spectrally-efficient technique that doubles data rates by simultaneously operating on both horizontal and vertical polarizations using the same channel frequency. XPIC is highly beneficial when only one channel frequency per path is available.

V-IPLink harnesses the power of ACM (Adaptive Coding Modulation), enabling dynamic adjustments to the modulation scheme, optimizing the transmission system based on prevailing path conditions, and maximizing the transported bit rate.

V-IPLink is available in both protected (1+1, 2+0, 1+0) and non-protected duplex configurations and can be designed for simplex operation, including spatial diversity receive systems.

Key Features

All-indoor, space-efficient 2RU x 19" (48 cm) rack mount

Ultra-high linearity broadband RF power amplifiers

Exceptional system gain performance

High capacity ASI & Gigabit Ethernet IP data transport

Automatic transmitter power control

Adaptive code modulation (ACM)

XPIC cross-polarization interference cancellation

ANSI and ETSI channel bandwidths selections

Intuitive web-based GUI for remote

Typical Applications

Studio-to-Transmitter Links (STL)

Transmitter-to-Studio Links (TSL)

Inter-city Relay Backhaul (ICR)

Multi-hop Microwave Relay Systems

High capacity IP Microwave Systems

Ideal for ATSC1.0/3.0 Lighthouse applications

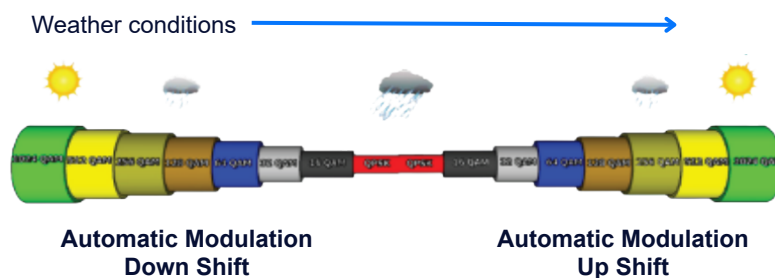

The Constellation Order will be selected on MER analysis and the highest and lowest are user selectable.

RF Parameters

- Frequency Bands**
- 1.9 - 2.7 GHz
 - 3.7 - 4.2 GHz
 - 4.4 - 4.9 GHz
 - 5.2 - 5.9 GHz
 - 5.9 - 6.4 GHz
 - 6.4 - 7.2 GHz
 - 6.8 - 7.4 GHz
 - 7.1 - 7.9 GHz
 - 7.7 - 8.5 GHz
 - 10 - 10.7 GHz
 - 11.7 - 12.4 GHz
 - 12.7 - 13.3 GHz
 - 14.25 - 14.5 GHz
 - 18 GHz
 - 23 GHz

- RF Output - Single Carrier**
- +39 dBm QPSK Modulation (3-14.5 GHz)
 - +33 dBm QAM Modulation (3-14.5 GHz)
 - +36 dBm QPSK Modulation (2 GHz)
 - +33 dBm QAM Modulation (2 GHz)

- RF Output Level - COFDM**
- +27.5 dBm (3-14.5 GHz)
 - +32.5 dBm (2 GHz)

Data Transport Parameters

- Modulations**
- QPSK, 16QAM, 64QAM, 128QAM, 256QAM, 512QAM, 1024QAM

- Throughput Capacity**
- 15 - 452 Mbps
 - Automatic Transmitter Power Control (ATPC)
 - Adaptive Code Modulation ACM (hitless switching, 0 ms interruption)

V-IPLink Rear Connection Options

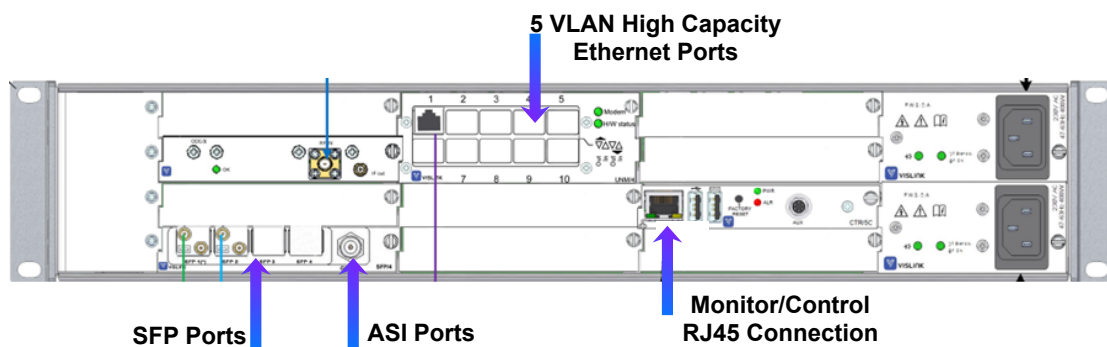

V-IPLink: Technical Specification

Output Interface

ODU Output Interface	<ul style="list-style-type: none"> • N Type Female Connector (2 GHz) • N Type Female Connector or Waveguide Flange PDR70 (WR137) (3/4/5/6/7 GHz) • Waveguide Flange PDR84 (WR112) (8 GHz) • Waveguide Flange UBR120 (WR75) (10/12/13/14 GHz) • Waveguide Flange PBR 220 (WR42) (18/23 GHz)
IDU Output Interface	<ul style="list-style-type: none"> • N Type Female Connector • TNC Femcal Connector • SMPTE 311 Fibre

Input Interface

ODU Input Interface	<ul style="list-style-type: none"> • N Type Female Connector • TNC Femcal Connector • SMPTE 311 Fibre
IDU Input Interface	<ul style="list-style-type: none"> • SFP Module - ASI • SFP Module - ETH (copper or Fibre)

User Interface Parameters

Ethernet Port Via SFP	6 Ethernet Ports
XPIC	Optional
STM-1 Port	1
ASI Port via SFP	4
ASI Packet Size	<ul style="list-style-type: none"> • 188/204 • Passes ISDB-T/BTS
Local & Remote Management	<ul style="list-style-type: none"> • 1 x 100/1000 Base T(RJ45)

Hot-Standby

ASI Transmit	2 x 1 DA
ASI Receive	2 x 1 A/B typ 40 msec
Ethernet TCP/IP Switch	600-1100 msec
System Management	1+1 with space diversity

Power

AC	110-240 VAC
-----------	-------------

Environmental

Operational Temp	-33 - +50° C (ODU) -5 - +45° C (IDU)
Storage Temp	-40 - +70° C (ODU)
Humidity	Max 95% non-condensing

Mechanical Specification IDU

Size	330 (L) x 480 (W) x 90 (H) mm 12.99" (L) x 18.89" (W) x 3.54" (H)
Weight	4 kgs 8.82 lbs

Mechanical Specification ODU

Size	270 (L) x 150 (W) x 120 (H) mm 10.62" (L) x 5.91" (W) x 4.72" (H)
Weight	5 kgs 11 lbs

E: sales@vislink.com | T: +1 908 852 3700 / +44 1442 431300 | www.vislink.com

© Copyright 2026 Vislink Technologies, Inc. All rights reserved. All other products or services referenced herein are identified by the trademarks or service marks of their respective companies or organizations. We reserve the right to change specifications without notice. Where applicable, versions of this device may not have been approved by the Federal Communications Commission (FCC). Where applicable, these versions are not offered for sale or lease until approval of the FCC has been obtained.

Ref TBC | Rev 1.0 | Mar 2026